

### Reed sensor For bypass level indicators Model BLR

KSR data sheet LM 10.04



for further approvals  
see page 3



#### Applications

- Sensor for the continuous level measurement of liquids in bypass level indicators
- Chemical, petrochemical industry, natural gas, offshore, shipbuilding, machine building, power generating equipment, power plants
- Process water and drinking water treatment, food and beverage industry, pharmaceutical industry

#### Special features

- Installation of head-mounted transmitters in the connection housing possible
- Wide variety of different electrical connections, process connections, materials and contact separations
- Programmable and configurable head-mounted transmitters for 4 ... 20 mA, HART®, PROFIBUS® PA or FOUNDATION™ Fieldbus field signals
- Explosion-protected versions
- Temperature ranges from -100 ... +350 °C



Reed sensor, model BLR-S

#### Description

The model BLR reed sensors are used for continuous monitoring and recording of the liquid level in connection with transmitters. They work on the float principle with magnetic transmission (permanent magnet, reed switch and resistance measuring chain) in a 3-wire potentiometer circuit.

A magnetic system built into the float actuates reed contacts, through the walls of the bypass chamber and of the sensor tube, in a resistance measuring chain (potentiometer). The measurement voltage generated by this is proportional to the fill level.







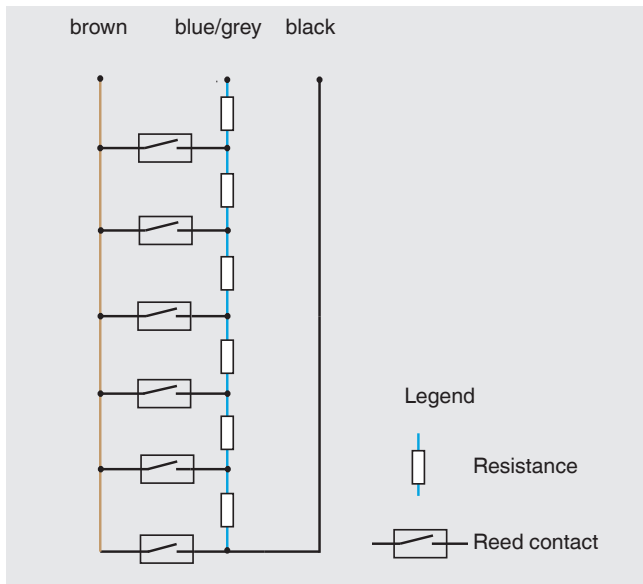



The resistance measuring chain is made up from reed contacts and resistors soldered onto a PCB. Depending on requirements and design several different contact separations from 5 to 18 mm are available.

For selecting the optimum sensor (sensor model, connection housing, electrical connection, sensor tube (material and total length), contact separation, head-mounted transmitter, measuring range, approval) we offer application-related technical advice.

## Internal circuit diagram of the reed sensors



## Approvals

Logo	Description	Country
 	<b>EU declaration of conformity</b> <ul style="list-style-type: none"> <li>■ EMC directive EN 61326 emission (group 1, class B) and interference immunity (industrial application)</li> <li>■ RoHS directive</li> <li>■ ATEX directive (option) Hazardous areas           <ul style="list-style-type: none"> <li>- Ex i II 2G Ex ia IIC T4 ... T6 Gb or II 2G Ex ib IIC T4 ... T6 Gb or II 2D Ex ib IIIC T80 °C Db No. KEMA 01 ATEX 1052 X</li> <li>- Ex d II 2G Ex d IIC T6 Gb or II 2D Ex tb IIIC T80 °C Db No. TÜV 13 ATEX 7399 X</li> </ul> </li> </ul>	European Union
	<b>IECEX (option)</b> Hazardous areas - Ex d Zone 1/2 -40 °C ≤ Ta ≤ +55 °C Ex d IIC T6 Ex tD A21 IP65 T80 °C No. IECEX TUR 09.0002X	International
	<b>EAC</b> <ul style="list-style-type: none"> <li>■ EMC directive No. TC N RU Д-DE.A301.B.00820</li> <li>■ Hazardous areas No. RU C-DE.ГБ08.B.01489</li> </ul>	Eurasian Economic Community
	<b>GOST</b> Metrology, measurement technology No. 19359	Russia
	<b>KazInMetr</b> Metrology, measurement technology No. 13947	Kazakhstan
	<b>BelGIM</b> Metrology, measurement technology No. 9711	Belarus
	<b>UkrSEPRO</b> Metrology, measurement technology No. UA-MI/2-4988-2015	Ukraine
	<b>Uzstandard</b> Metrology, measurement technology No. 02.6649	Uzbekistan
-	<b>PESO</b> Hazardous areas No. P331149/1	India
	<b>DNV GL</b> Ships, shipbuilding No. TAA00000M2	International

Approvals and certificates, see website

## Reed sensor, standard version with connection housing

### Models BLR-SA, BLR-SB

Guide tube and float made of 1.4571 stainless steel

Aluminium and polyester connection housing

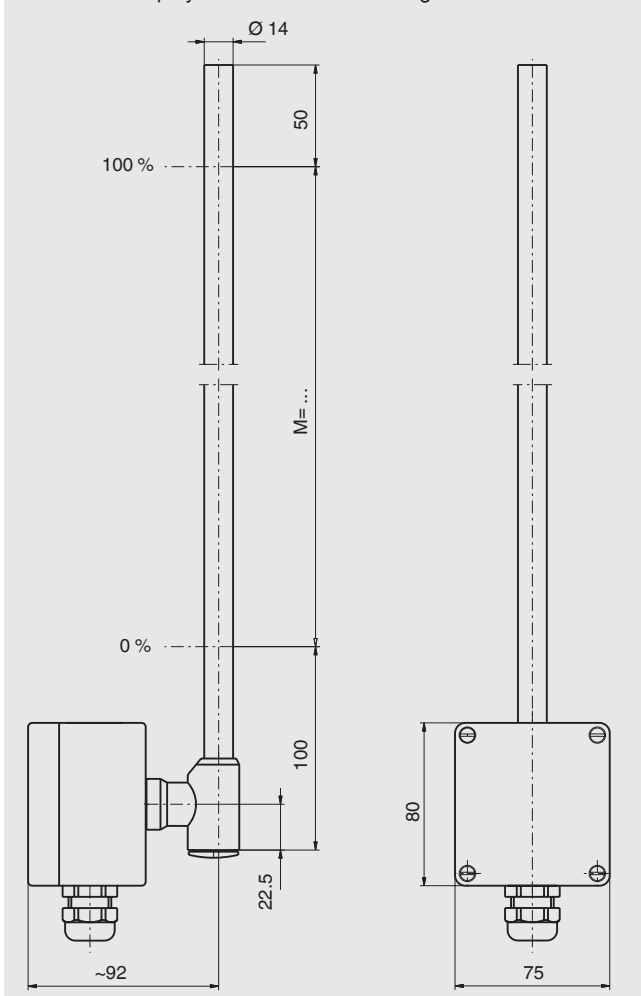

Stainless steel connection housing

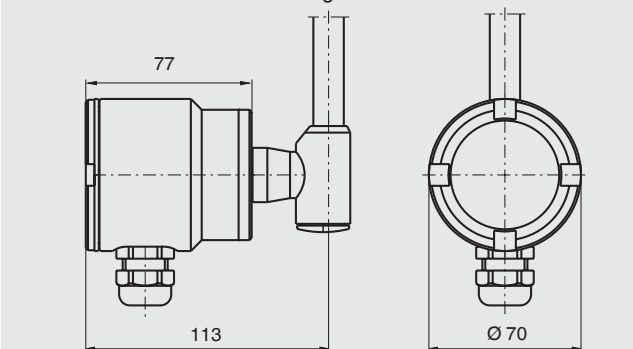

Stainless steel connection housing with digital indicator (option)

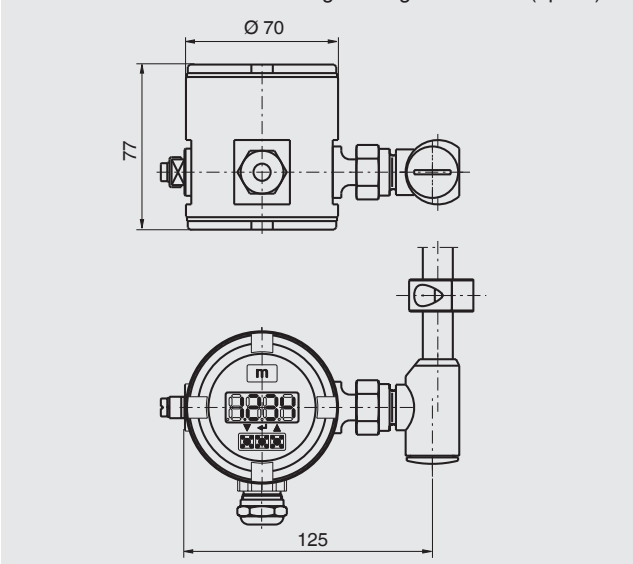

	Model BLR-SA	Model BLR-SB
<b>Electrical connection</b>	Connection housing: Aluminium 80 x 75 x 57 mm Option: Polypropylene, polyester, stainless steel	Connection housing: Aluminium 80 x 75 x 57 mm with head-mounted transmitter Option: Polypropylene, polyester, stainless steel
<b>Guide tube diameter</b>	14 mm	
<b>Temperature range</b>	<ul style="list-style-type: none"> <li>■ Standard version -50 ... +100 °C</li> <li>■ High-temperature version -50 ... +200 °C</li> <li>■ Low-temperature version -100 ... +100 °C</li> <li>■ Standard version with Mikroterm -50 ... +250 °C</li> <li>■ High-temperature version with Mikroterm -50 ... +350 °C</li> </ul>	
<b>Resolution</b>	2.7 mm / 5.5 mm / 7.5 mm / 9 mm (depending on contact separation)	
<b>Overall resistance of the measuring chain</b>	Depending on length and separation	
<b>Head-mounted transmitter</b>	External transmitter	Head-mounted transmitter, see page 7
<b>Output</b>	3-wire potentiometer	4 ... 20 mA
<b>Permissible power supply</b>	< AC 50 V, < DC 75 V	See the data sheet of the head-mounted transmitter used
<b>Ingress protection</b>	up to IP66 or IP68 per IEC/EN 60529 (depending on version)	

# Reed sensor, explosion-protected version Ex i, intrinsically safe Models BLR-SAI, BLR-SBI (MG...)



KEMA 01 ATEX 1052 X (II 2G Ex ia IIC T4 ... T6 Gb, II 2D Ex ib IIC T4 ... T6 Gb or II 2 D Ex ib IIIC T80 °C Db)  
Guide tube and float made of 1.4571 stainless steel

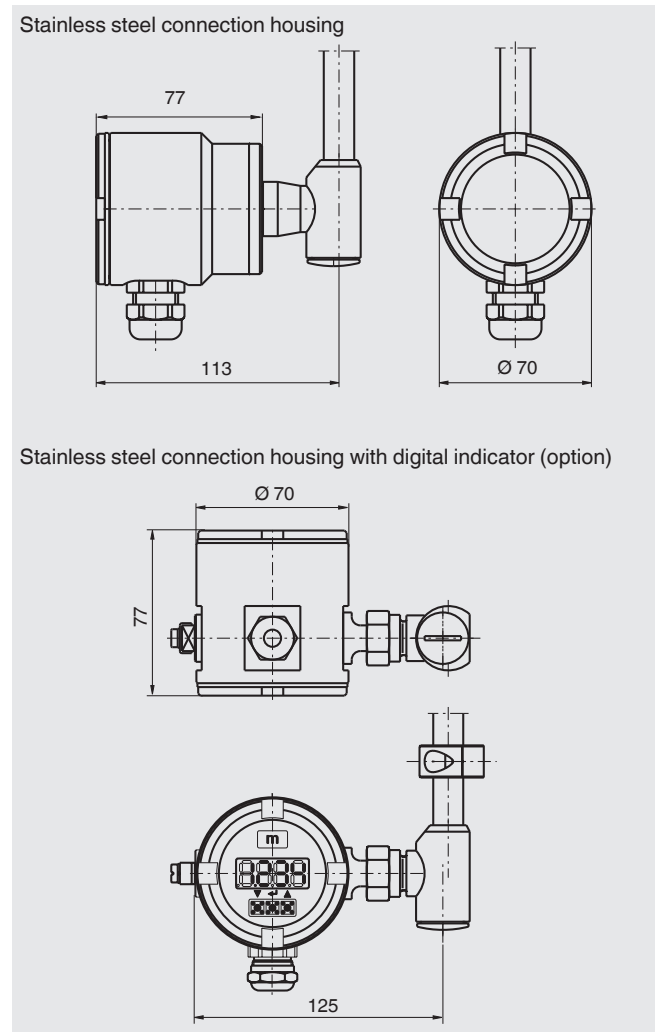
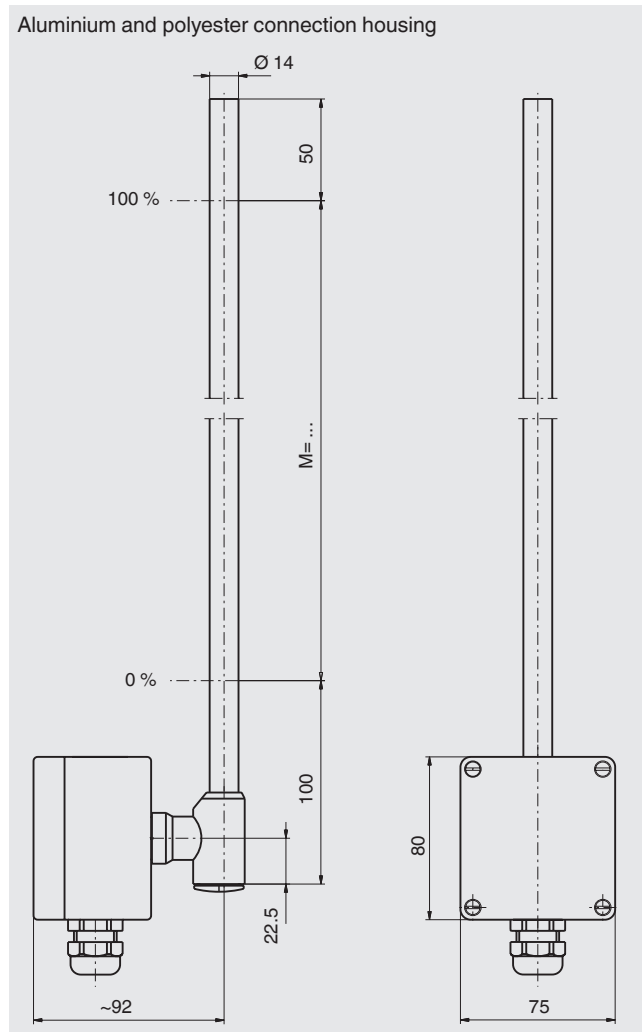

	Model BLR-SAI (MG...)	Model BLR-SBI (MG...)
<b>Electrical connection</b>	Connection housing: Aluminium 80 x 75 x 57 mm Option: Stainless steel	Connection housing: Aluminium 80 x 75 x 57 mm with head-mounted transmitter Option: Stainless steel
<b>Guide tube diameter</b>	14 mm	
<b>Maximum permissible surface temperature at the sensor tube</b>	T4: +100 °C T5: +65 °C T6: +50 °C	
<b>Resolution</b>	2.7 mm / 5.5 mm / 7.5 mm / 9 mm (depending on contact separation)	
<b>Overall resistance of the measuring chain</b>	3.2 ... 50 kΩ	
<b>Control circuit</b>	Ignition protection type Ex ia IIC (only for connection to a certified intrinsically safe control circuit) and ignition protection type intrinsically safe Ex ib IIC	
<b>Head-mounted transmitter</b>	External transmitter	Head-mounted transmitter, see page 7
<b>Output</b>	3-wire potentiometer	4 ... 20 mA
<b>Permissible power supply</b>	< AC 50 V, < DC 75 V	See the data sheet of the head-mounted transmitter used
<b>Ingress protection</b>	up to IP66 or IP68 per IEC/EN 60529 (depending on version)	

## Reed sensor, explosion-protected version Ex d, flameproof enclosure

### Models BLR-SAD, BLR-SBD (AVK-ADF)

TÜV 13 ATEX 7399 X (II 2G Ex d IIC T6 Gb / II 2 D Ex tb IIIC T80 °C Db)

IECEX TUR 09.0002X (-40 °C ≤ T<sub>a</sub> ≤ +55 °C Ex d IIC T6 Ex tD A21 IP65 T80 °C)

Guide tube and float made of 1.4571 stainless steel

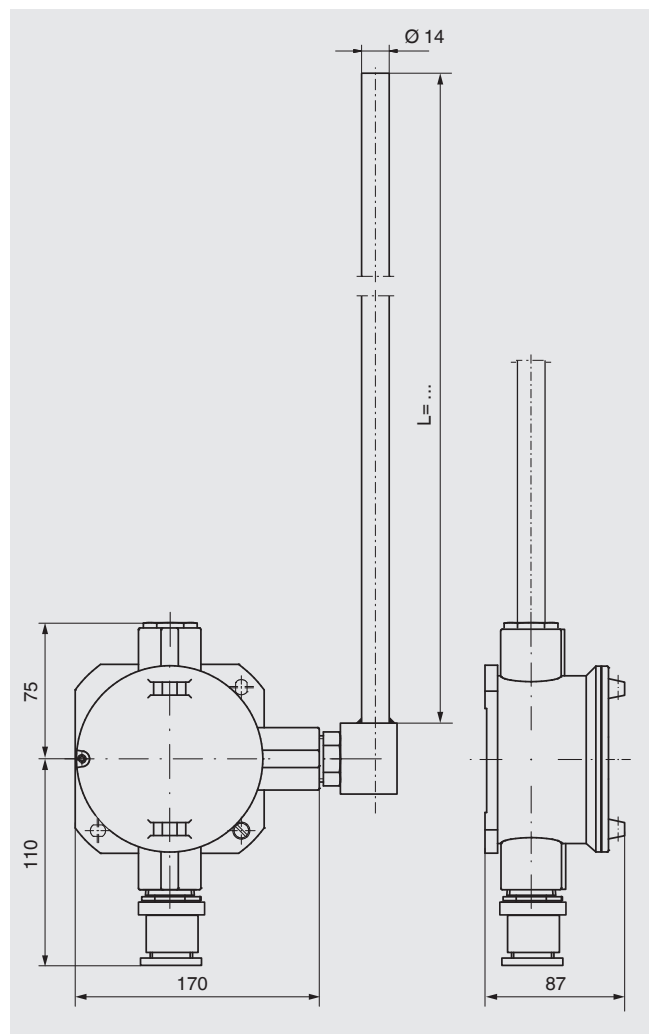

	Model BLR-SAD (AVK-ADF)	Model BLR-SBD (AVK-ADF)
<b>Electrical connection</b>	Connection housing: Aluminium 170 x 151 x 87 mm Option: Stainless steel	Connection housing: Aluminium 170 x 151 x 87 mm with head-mounted transmitter
<b>Guide tube diameter</b>	14 mm	
<b>Maximum permissible surface temperature at the sensor tube</b>	T4: +100 °C T5: +65 °C T6: +50 °C	
<b>Resolution</b>	2.7 mm / 5.5 mm / 7.5 mm / 9 mm (depending on contact separation)	
<b>Overall resistance of the measuring chain</b>	Depending on length and separation	
<b>Head-mounted transmitter</b>	External transmitter	Head-mounted transmitter, see page 7
<b>Output</b>	3-wire potentiometer	4 ... 20 mA
<b>Permissible power supply</b>	< AC 50 V, < DC 75 V	See the data sheet of the head-mounted transmitter used
<b>Ingress protection</b>	up to IP66 or IP68 per IEC/EN 60529 (depending on version)	

## Head-mounted transmitter

Model T15



Model T32



Model T53



Model TLEH



Model	4 ... 20 mA	HART®	PROFIBUS® PA	FOUNDATION™ Fieldbus	Ex i	Display	Order no.
TE	x				x		014832
TS	x						005894
T32E	x	x			x		025216
T32S	x	x					114795
T53F				x	x		025727
T53P			x		x		034422
TLH	x	x				x	019989
TLEH	x	x			x	x	021104
T15	x				x		122955 122954

### Ordering information

Model / Connection housing / Electrical connection / Sensor tube (material and total length) / Contact separation, head-mounted transmitter / Measuring range / Approval / Options

To order the described product the order number (if available) is sufficient.

© 08/2014 KSR KUEBLER Niveau-Messtechnik AG, all rights reserved.  
The specifications given in this document represent the state of engineering at the time of publishing.  
We reserve the right to make modifications to the specifications and materials.

KSR data sheet LM 10.04 · 07/2017

Page 7 of 7

NORWEGIAN DISTRIBUTOR: HAAKON ELLINGSEN AS

Haakon Ellingsen AS

Årenga 8, N-1340 Skui P.O. Box 184, N-1309 Rud  
Phone +47 67151200

sales@haakonellingsen.no  
www.haakonellingsen.no

 HAAKON ELLINGSEN AS

 KSR KUEBLER  
A division of the WIKA group